

50 years of combi ovens



50 years
of global market
leadership
for professional
cooking systems.

Investor Relations Presentation Fiscal Year 2025
Landsberg am Lech, 19 March 2026

1 Our Products and Services



iCombi Pro

The WOW Effect



The intelligent combination of heat and moisture.



**Saves time,
energy and
money.**

Covers

95%

of all cooking
applications.

Convection oven
and steamer in
one

Integrated
cooking
intelligence

Professional food
preparation

Reliable results



RATIONAL

iHexagon

Auftaut
00:00
Ende
28:05 m:s



iHexagon

Beginning of a New Era



Specialist for the highest food quality in the shortest possible time.



**Steam, convection
heat and microwave
energy are intelligently
coordinated**

On all six racks.



iHexagon

Highest food
quality in the
shortest possible
time.



Up to **30%**
time savings



Boosted
productivity



Boosted
flexibility

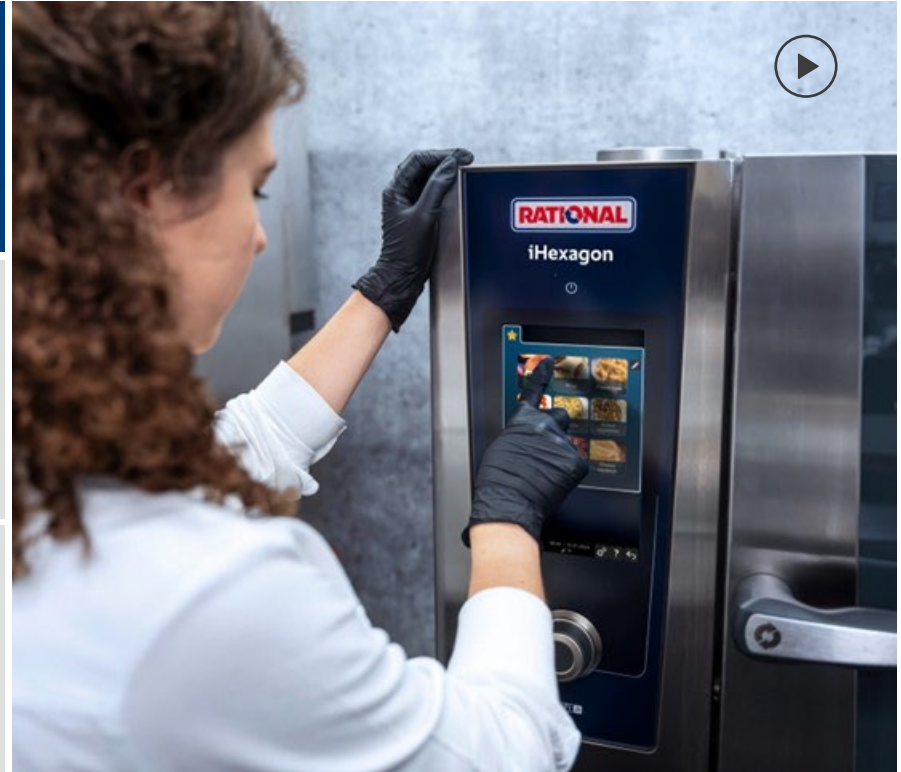

iVario Pro

The Game Changer



For catering and restaurants



**Like stoves or
tilting pans –
continuously
evolved.**



iVario Pro L



iVario 2-S



iVario Pro XL



iVario 2-XS

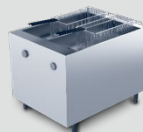

Designed to replace conventional bratt pans, boiling kettles, deep-fryers and pressure cookers.



Designed to replace saucepans, frying pans, deep fryers, pressure cookers, planchas, pasta cookers and bain-maries.



ConnectedCooking

Digital platform for RATIONAL cooking systems

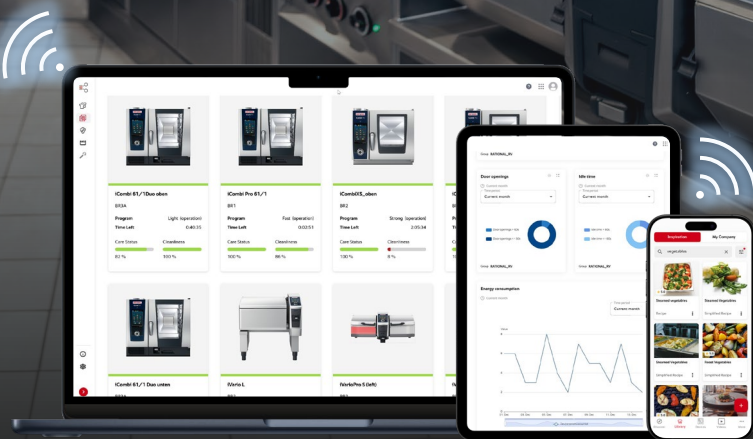

The digital backbone of RATIONAL cooking systems



One central platform for connected cooking systems

Cloud solution with the highest level of **data protection** and **security**

More than **190.000 user** and **130.000 connected units**

Scalable from a single kitchen to a chain

Connects RATIONAL units, users, and digital services in a **single solution**





First-class services

For greater customer benefit



Expert
Advice



Starter
Training



RATIONAL
Academy



ChefLine®

RATIONAL Technical Service

Always at the customer's service



Original service parts



Certified service partners



Professional installation



Digital Service



Global service network

Products and services

Revenue breakdown - Equipment revenue is supplemented by recurring non-equipment revenue

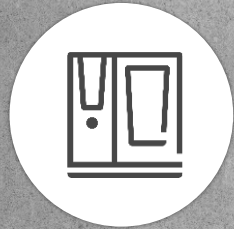

iCombi

Worldwide sales of combi ovens

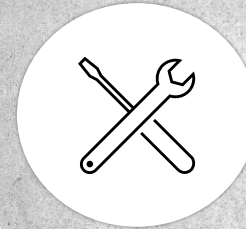
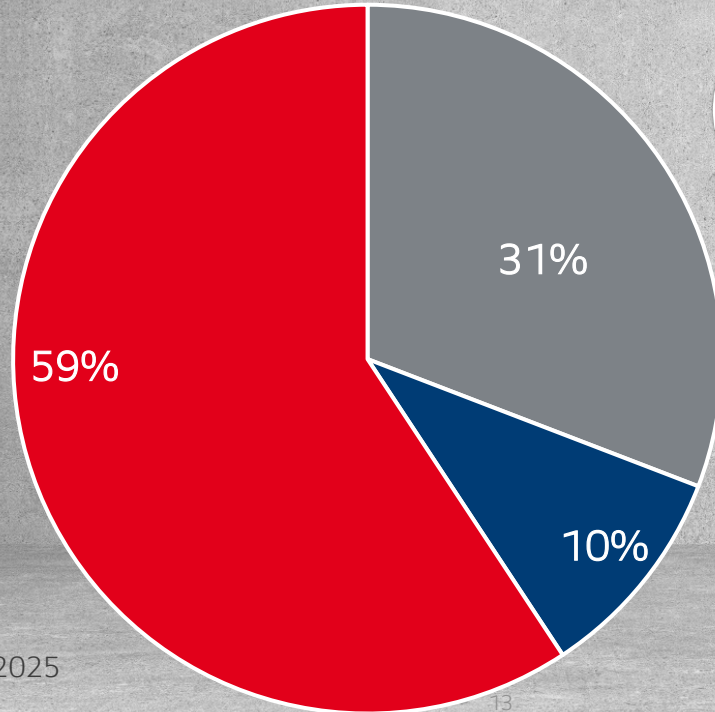

Aftersales business

Accessories, service parts, cleaners, and services

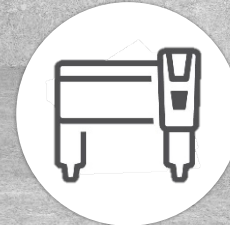

iVario

Worldwide sales of multifunctional cooking systems

Based on sales revenues FY 2025

2 Sustainability and resource efficiency



An investment that pays off

For environment, cash flow & future

Comparison of **space requirements** in sample kitchen for 700 meals, 3 menus*:

RATIONAL cooking systems:

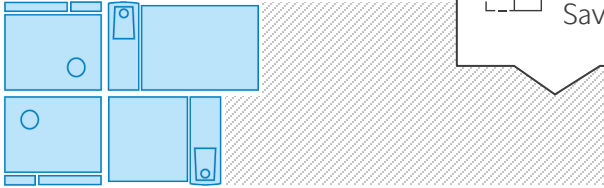

Conventional technology:

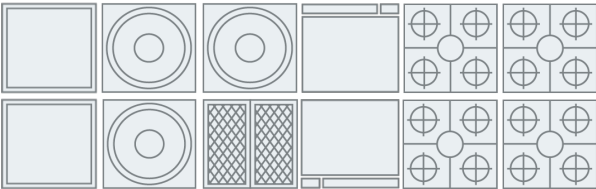

*Research project by Zurich University, using ABB Schweiz AG as an example





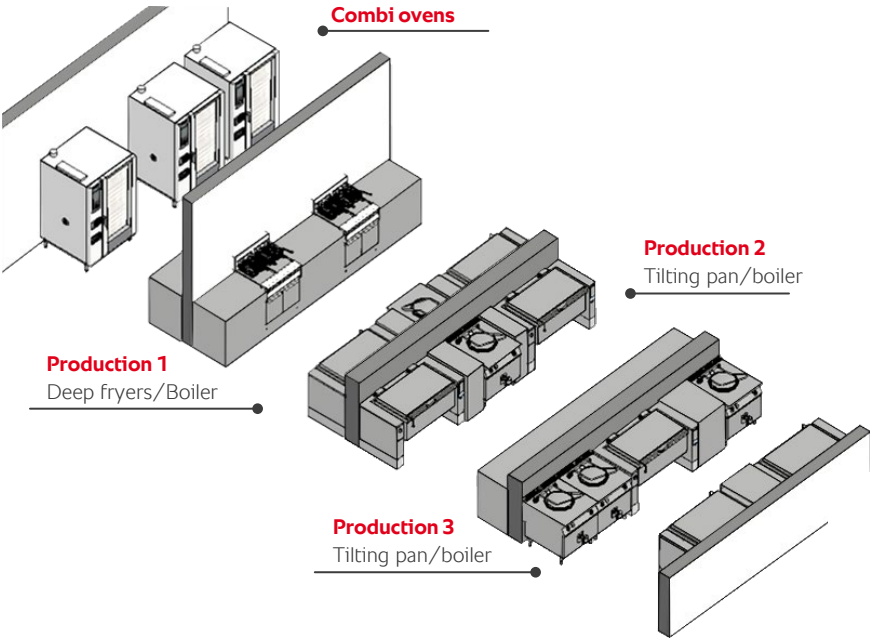

Initial situation, objectives & measurement in company restaurant

Old kitchen



Study objectives

 <p>Saving potentials for energy & water consumption, peak power</p>	 <p>Increase food quality</p>
 <p>Improvement of work processes Consideration of traditional vs. modern processes</p>	 <p>Identifying the benefits of modern cooking systems for a better work quality</p>

The measurement

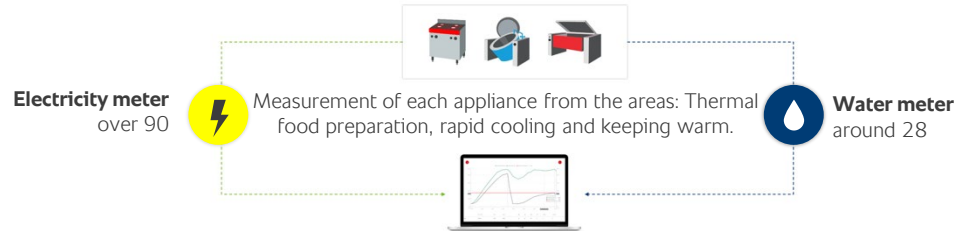

Total: **79 production days** in measurement period 1 and **80 production days** in measurement period 2

Study AXA AG

Study results

New **RATIONAL** kitchen

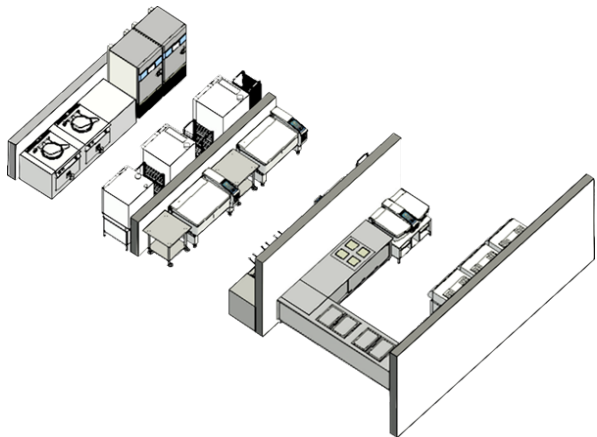

47.9%

Less
water

24.1%

Less
energy

20.2%

Lower
connected load

>20%

Lower
power peaks



3 Our customers





For kitchens

In which 20 or 70,000
meals are prepared

Our customers worldwide



Establishments with over 20 meals per service

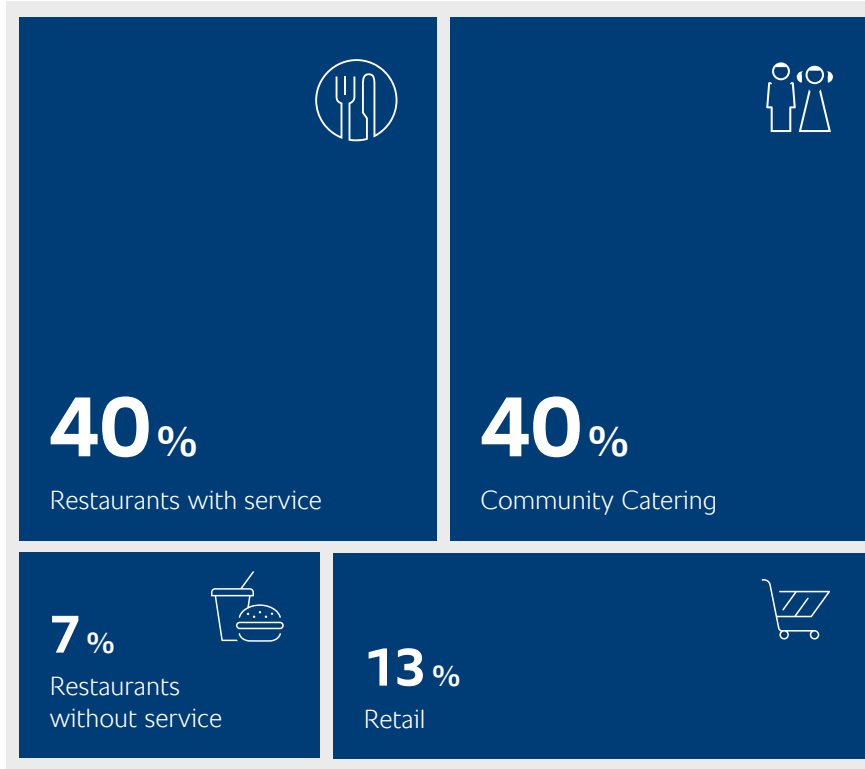

Graphic refers to the number of sold appliances

Above-average customer satisfaction

+60

RATIONAL AG

Slight decrease of NPS since
2022 (+64)

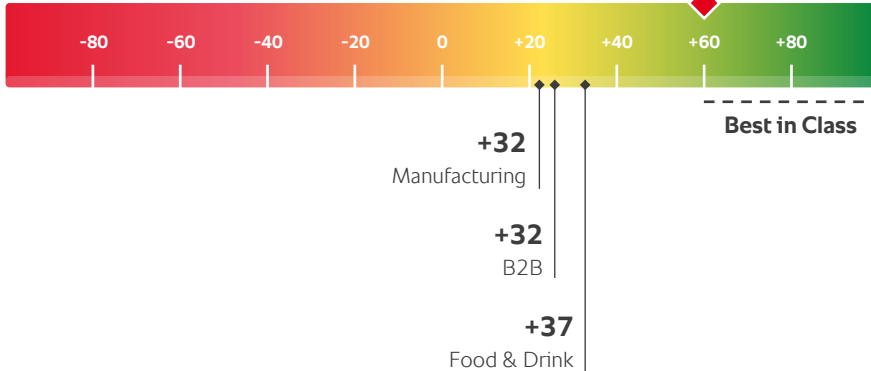

High untapped market potential for both product groups



Aiming to substitute traditional equipment in professional kitchens

75%

Traditional appliances

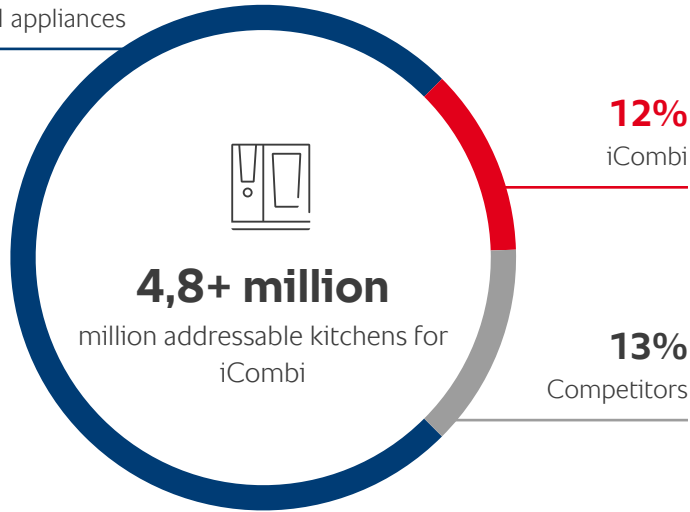

92%

Traditional appliances

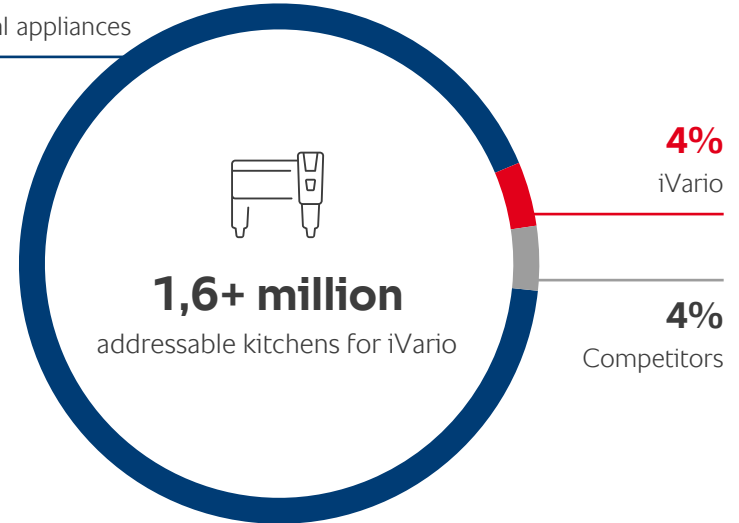

4 Our History





"In this day and age, a company has a right to exist when it fulfills its task and that task is to offer benefit to the customer. The quality of this benefit determines success or failure."

Siegfried Meister
*1938 - †2017

1973

Company founded



Invention of the first
RATIONAL **combi**
oven **CD 101**

1976



Invention of the
ClimaPlus Combi

1997

1979



Implementation of the
bottleneck-concentrated
strategy

1996



Production of the
100,000th
combi oven



Launch of
SelfCookingCenter &
VarioCookingCenter



Introduction of
ConnectedCooking

2000

2004

2017

2018



RATIONAL IPO



FRIMA becomes RATIONAL



Launch of
iCombi & iVario

2020



Introduction of a new
product category –
iHexagon and **digital**
products

2024

2026

Opening of a third
production site in
Suzhou, China



Production of the
1.5th million
combi oven



1973

Heute

Everything for one goal:
Extremely satisfied customers

Anniversary

50 Years RATIONAL

In 2023 we celebrated our anniversary with several internal and external activities.



When it tastes great, we all speak the same language. **Roll the film!**

Global presence



1.000+

chefs with culinary expertise and experience



120+

countries with local presence

3

Production sites

32

Subsidiaries

4.000+

partners worldwide



600

Patents

5 International success stories





On the mountain
Café 3440 on Pitztal Glacier



In the air

gategroup. Airline catering.





On the water

Scenic Eclipse. The World's
First Discovery Yachts.



6 Recipe for success



Maximum customer benefit as our primary corporate aim

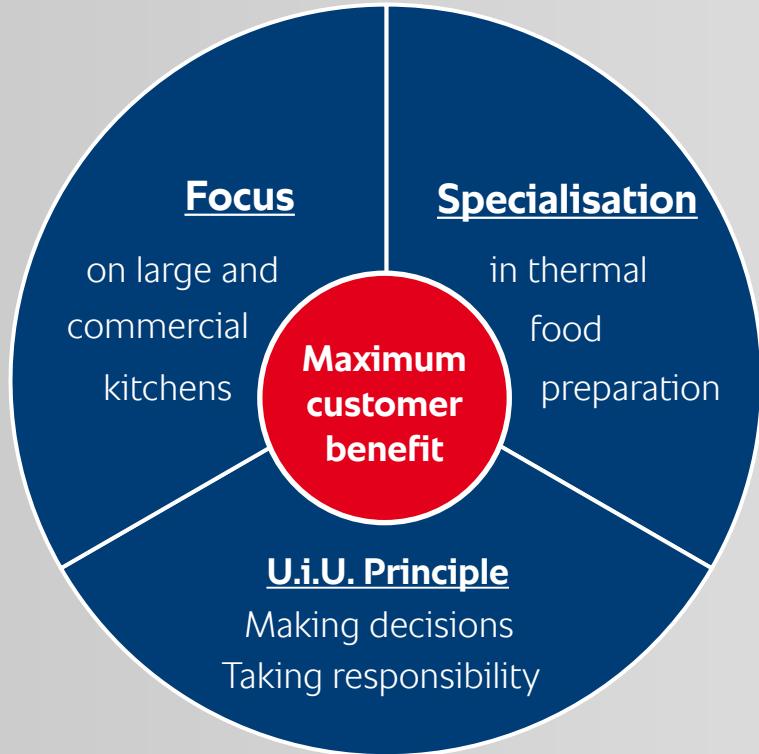

Our utmost objective

We want to offer maximum benefits to those preparing hot food in large and commercial kitchens, as well as the best solutions for their daily kitchen routines and the best cooking support. For more than 50 years, this has been our rule of etiquette. And dictates how we act with our customers, suppliers, employees and investors. Undoubtedly the reason why 93% of our customers worldwide confirm that RATIONAL offers maximum customer benefit.

Greater customer benefit

Higher profits

Cost depression

Higher productivity

Customer benefit

Greater attraction

Increased demand

Positive learning curve

Growth



With employees
Who are committed and inspired

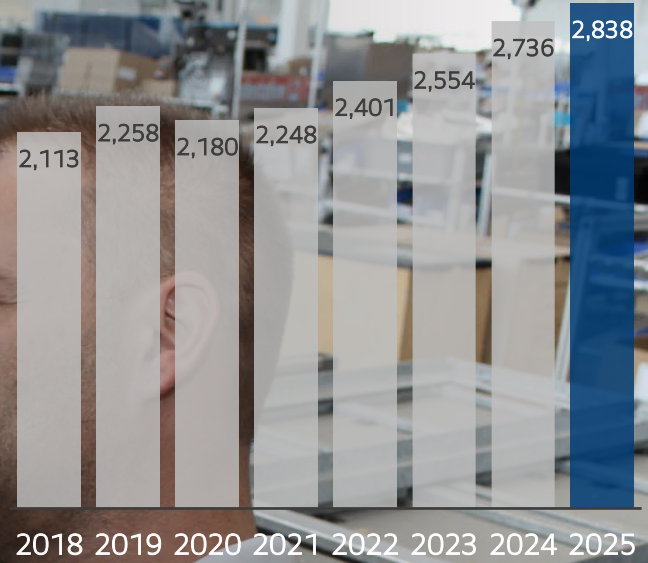

U.i.U. Compass 2024:

- 90%** All in all very satisfied or satisfied with RATIONAL as employer
- 88%** Are proud to work at RATIONAL



With courage

To reinvent customer benefit

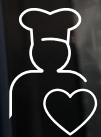

With 1,000 chefs
At work every day



4 Köche, 4 Reisen



ALZSTAR 23-T/S ALZMETALL

Metalworking Training



With new talents
Committed apprentices and students



With responsibility
For people and the environment



Markus Paschmann
CSMO

Jörg Walter
CFO

Dr. Martin Hermann
CTO

Dr. Peter Stadelmann
CEO

7 Business situation and outlook



Sales up 6% – +8% currency-neutral growth

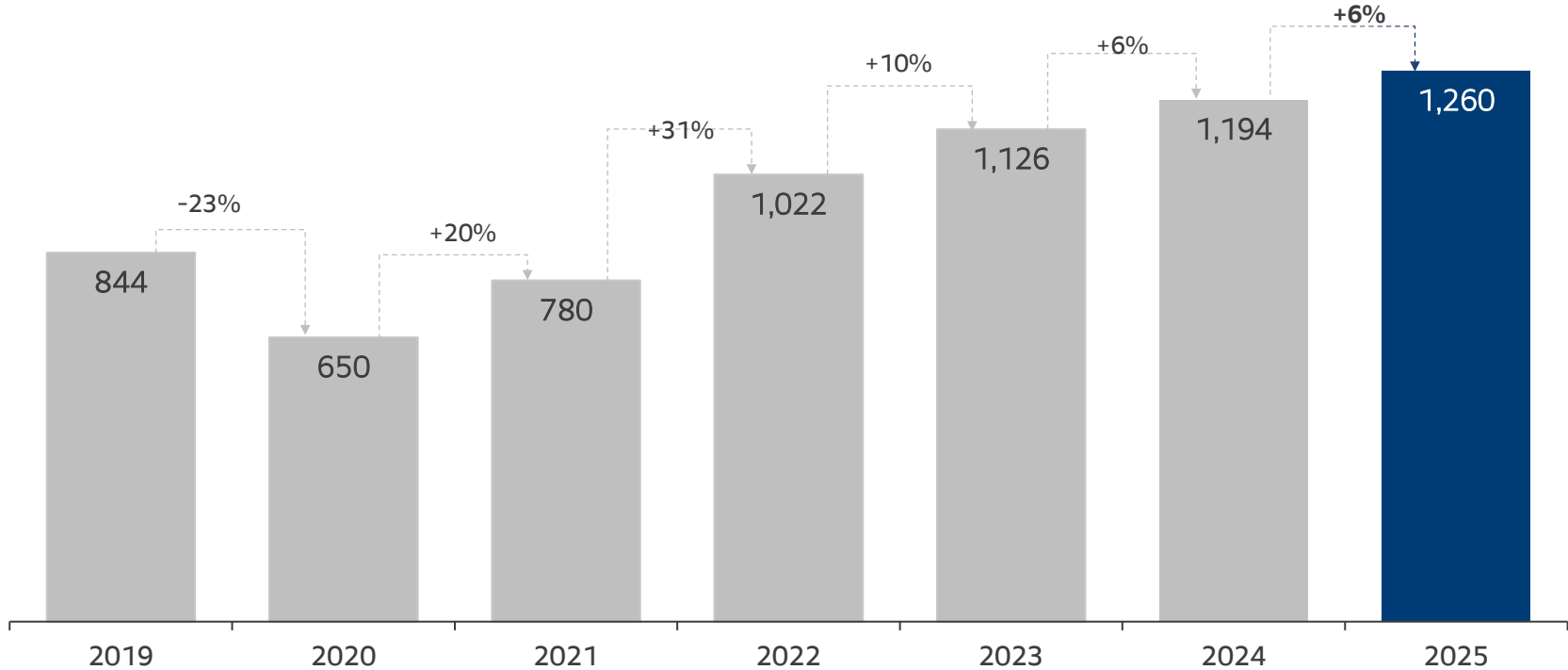

Q4 2025 – Sales revenues reach another all-time high

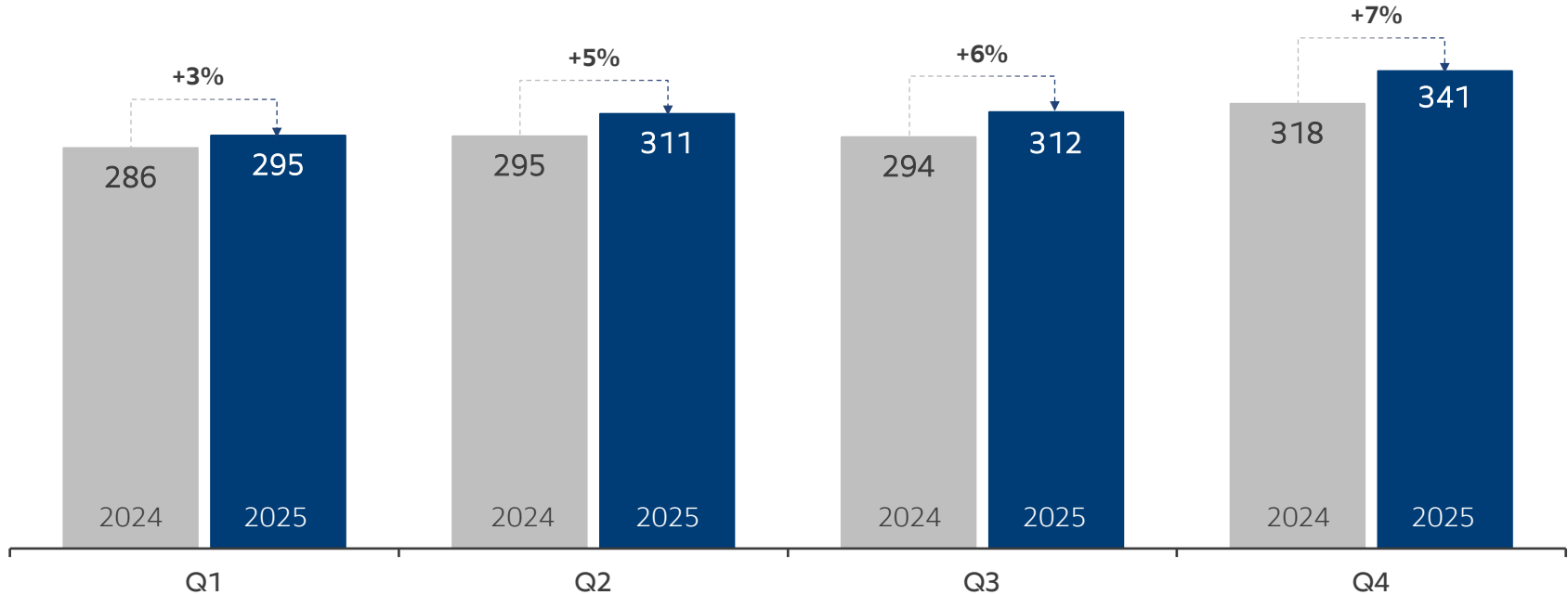

North America and Europe as growth drivers

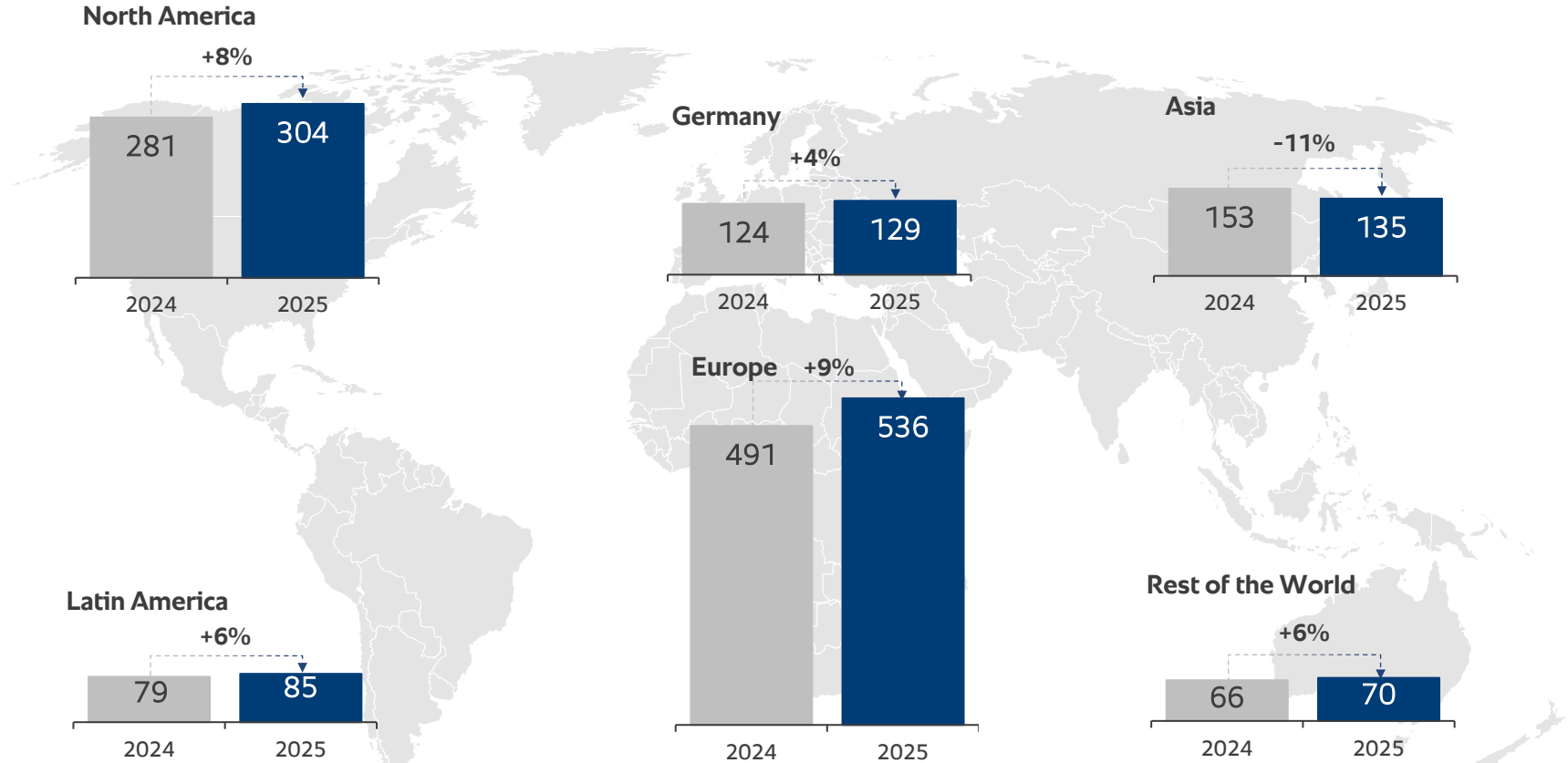

■ Sales revenues in million euros | Revenue growth compared to the previous year.

Solid growth in both product groups

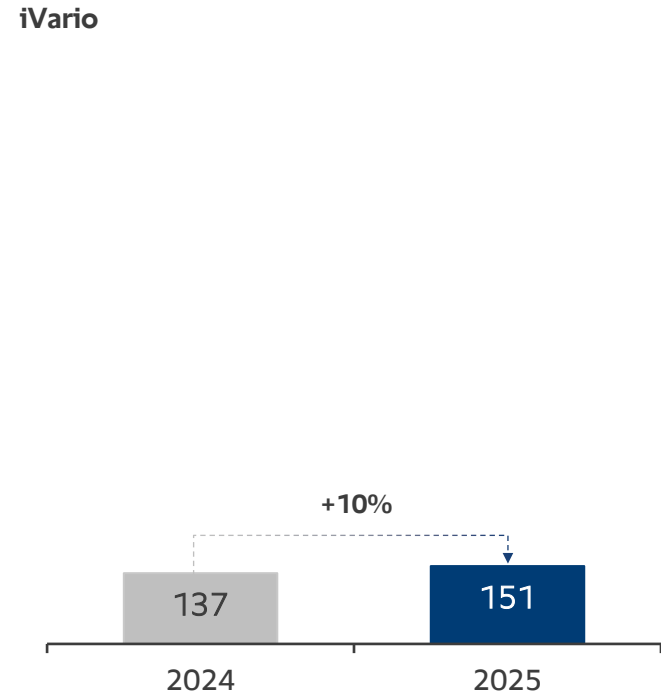
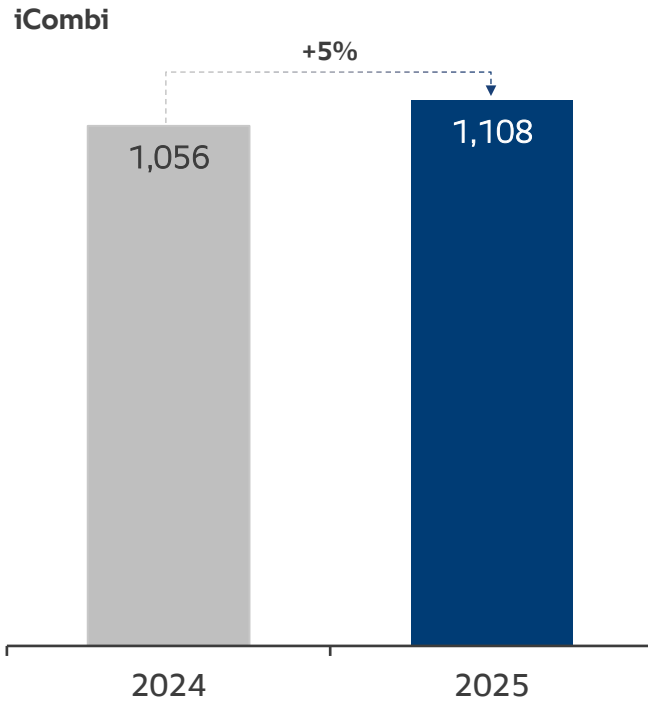

EBIT margin slightly exceeds expectations

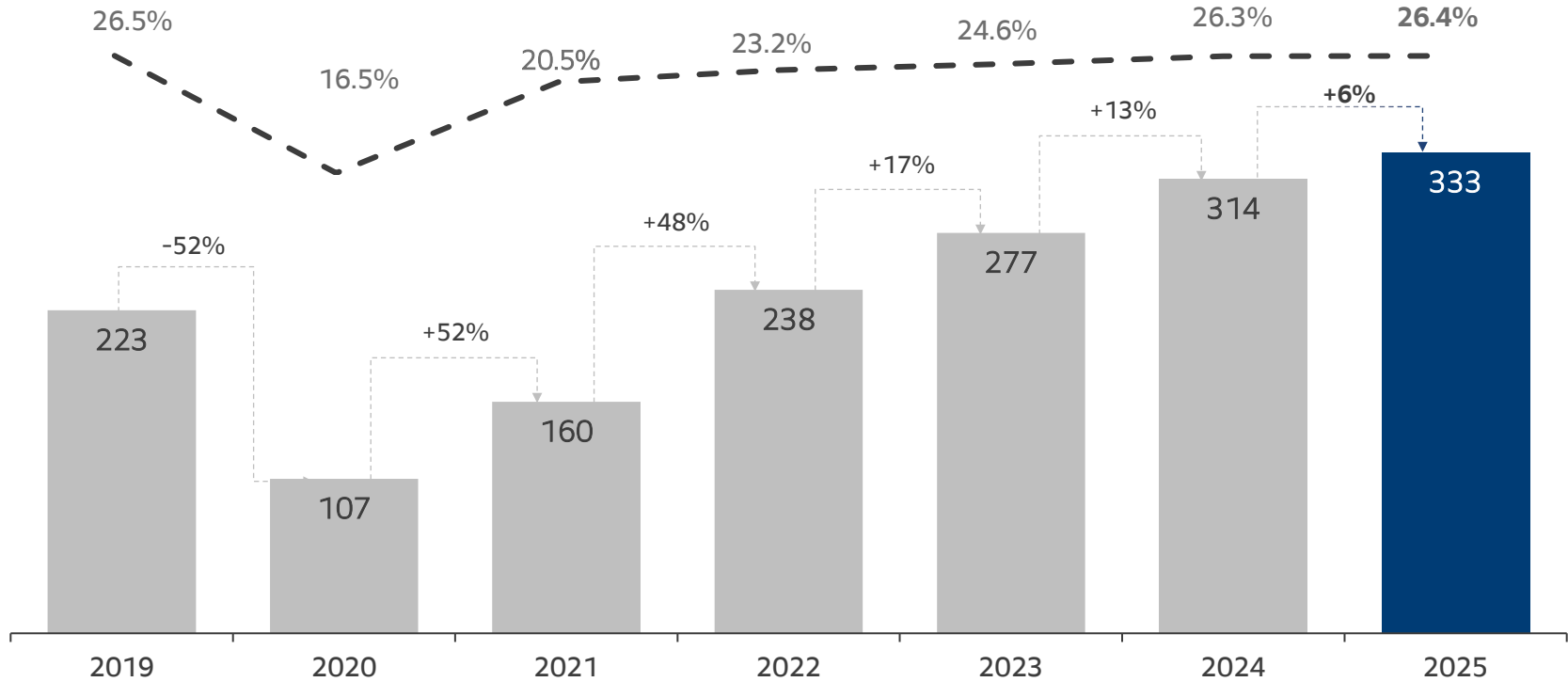

High profitability in FY 2025

Healthy sales revenue performance and favourable COGS

in m EUR	2024	2025	2024 vs. 2025	
			Change	Margin Impact
Sales revenues	1,194	1,260	+6%	---
COGS	-487	-516	0%	-20 bps
Gross Profit	707	743	+5%	-20 bps
Gross Margin	59.2%	59.0%	---	-20 bps
Sales and Service	-265	-282	+6%	-20 bps
R&D	-66	-76	+15%	-50 bps
Administration	-55	-54	-2%	+30 bps
Operating Expenses	-385	-411	+7%	
Other operating in./exp.	2	+2	---	+10 bps
Currency Result	-9	-2	---	+60 bps
EBIT	314	333	+6%	---
EBIT Margin	26.3%	26.4%	---	+10 bps



Sales revenues growth in line with expectations



COGS: additional costs due to US tariffs partly compensated by productivity gains and slightly lower material costs



Targeted increase in **operating expenses**

High equity ratio and liquidity

in m EUR	31.12.2024	31.12.2025
Non-current assets	292	289
Inventories	108	124
Trade receivables	181	200
Other assets	373	383
Liquid funds	152	186
Total assets	1,106	1,183
Equity	857	941
Non-current liabilities	45	43
Current provisions	82	88
Current liabilities	122	112
Equity & liabilities (total)	1,106	1,183

Balance sheet at a glance:

- 7% growth in total assets
- 46% Liquidity ratio¹
- 48 DSO (days)
- 22% Working Capital/ Sales revenues²
- 80% Equity ratio

¹Bank deposits and short-term investments

²Working Capital: Trade inventories and receivables less trade payables and advance payments received as a percentage of 2025 sales.

Long-term business model with low investment intensity

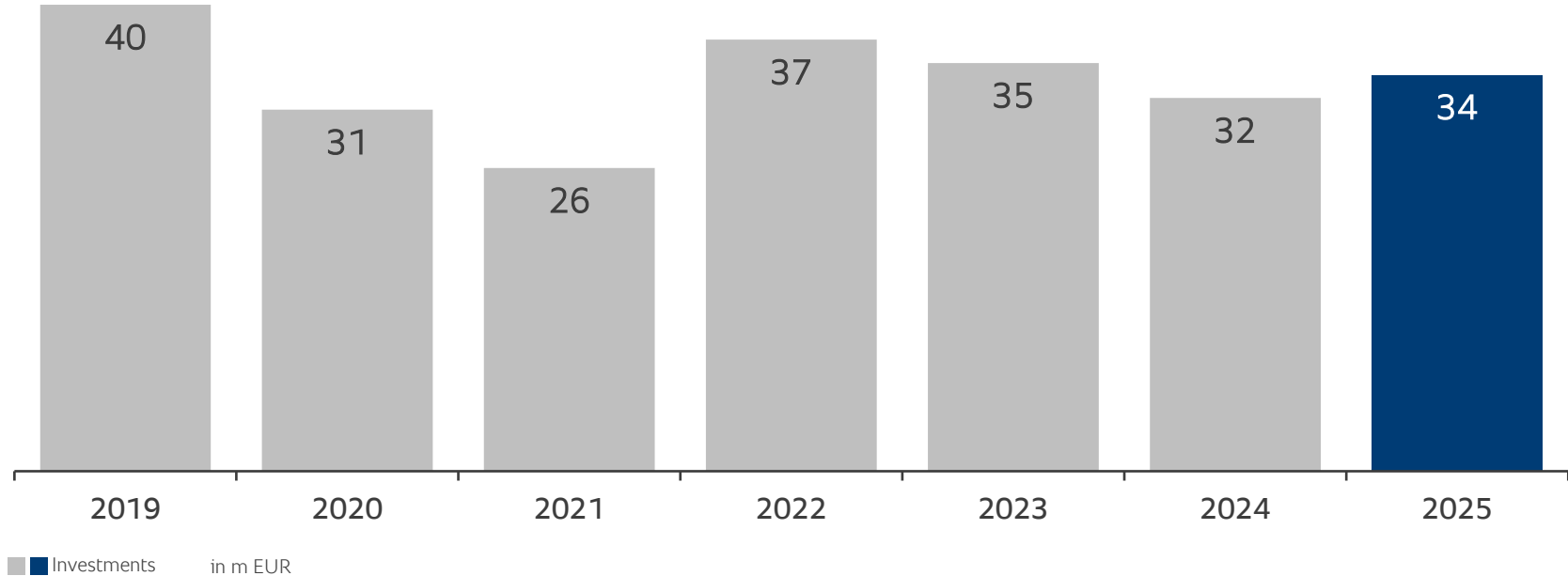

The new service parts distribution center

The largest investment in the history of RATIONAL



RATIONAL



Opening
Spring 2027

Kick-off project

Spring 2023



- Automated high-bay and shuttle warehouse
- 7,579 m² built area and
- Planning according to the latest sustainability standards
- Investment volume of around 60 m EUR



The home of the iVario Wittenheim, France

**Opening of the
new plant**
Spring 2024



Relocation of production
October 2025



- 100,000 m² land area
- 10,000 m² production area
- Current capacity 25,000 iVario
- Investment volume around 30 m EUR

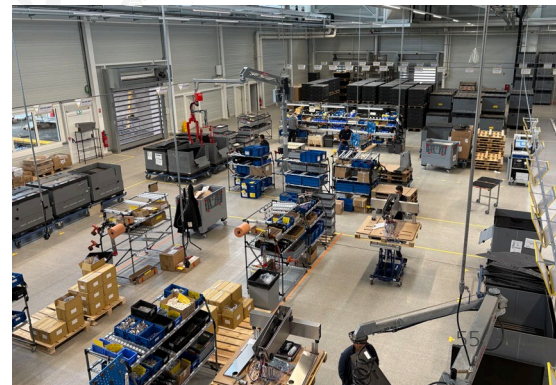

Road to China

A combi oven especially for the Chinese market

RATIONAL



Start of renovation

July 2023



Opening of the new plant

March 2024



Market launch

March 2026



Dividend



Dividend 2025 of EUR 20.00 proposed

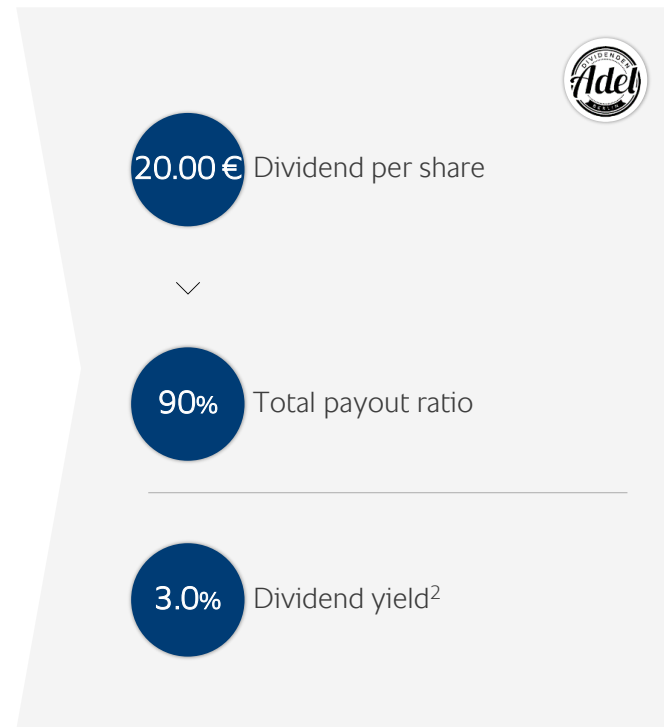
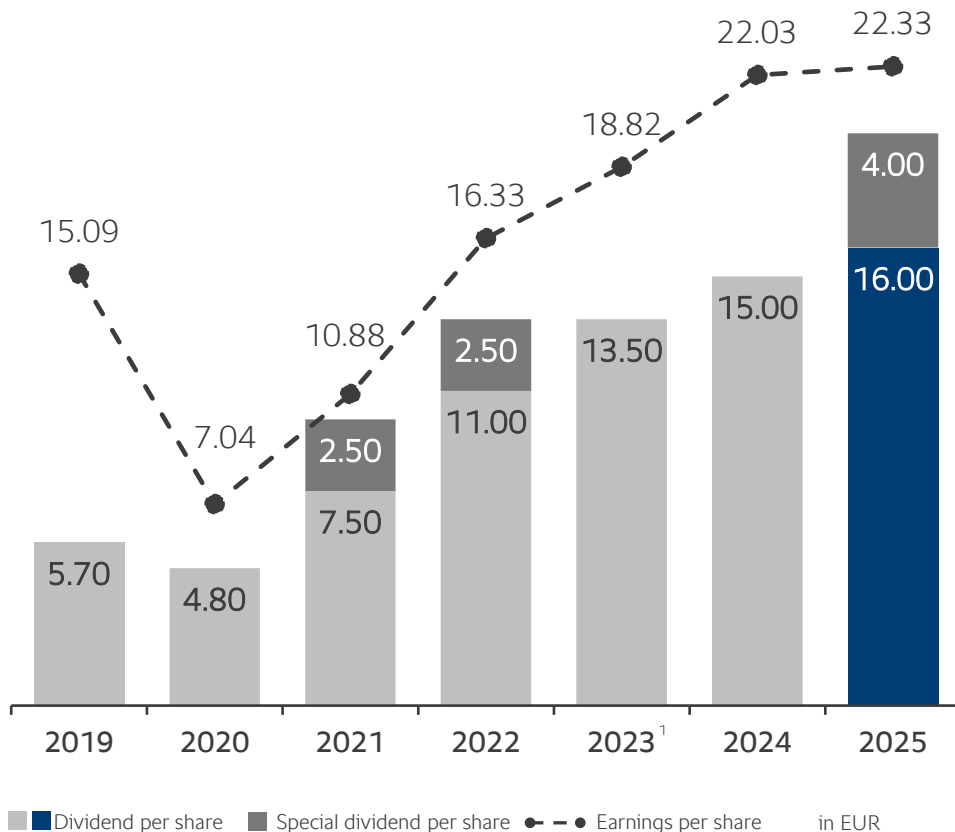

¹The comparative figures for the previous year have been retrospectively adjusted in accordance with IAS 8 (see section "Consolidation, accounting and measurement policies – deferred taxes").

²Based on the 2025 year-end share

Cautiously optimistic – despite economic challenges



Sales revenue growth

In the mid to high single-digit percentage range.

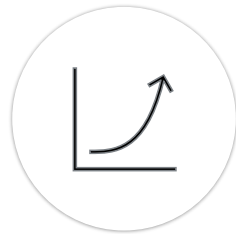

Gross profit margin

on a slightly lower level than in the previous year.



Operating costs

are rising slightly faster than sales revenues.



EBIT margin

between 25% and 26%.

RATIONAL – Opportunities and strengths profile

Opportunities

- › Rising energy, rent and personnel costs
- › Increasing shortage of skilled workers
- › Increasing hygiene requirements for commercial kitchens
- › High demand for healthy and varied food
- › Rising purchasing power in emerging markets



Strengths

- › Technologically leading cooking systems, market leading networking solutions
- › High brand awareness and customer loyalty
- › High untapped market potential
- › High profitability and financial strength
- › Satisfied employees
- › Reducing the energy and resource footprint in industrial kitchens

Investor relations contact



Financial calendar

Company information

RATIONAL AG
Siegfried-Meister-Straße 1
86899 Landsberg am Lech
Germany
www.rational-online.com

Calendar 2026

19.03.2026	Financial Figures Fiscal Year 2025 (Munich/virtual)
29.04.2026	General Shareholder' Meeting 2025 (Augsburg)
06.05.2026	Financial Figures Q1 2026 (virtual)
06.08.2026	Financial Figures HY 2026 (virtual)
05.11.2026	Financial Figures 9M 2026 (virtual)
19.11.2026	Capital Markets Day 2026 (tbd)

Investor Relations Contact

Stefan Arnold
Tel.: +49 8191 327 2209

Laura Deininger
Tel.: +49 8191 327 2792

ir@rational-online.com

Roadshows and conferences

08.04.2026	BNP Paribas, Roadshow, Paris
12.05.2026	UBS Pan European Small and Mid-Cap Symposium, London
18.05.2026	NRA Show, Chicago
19.05.2026	Berenberg European Conference, New York
20.05.2026	Roadshow, Canada
22.05.2026	Bernstein Conference, Nice
26.05.2026	dbAccess European Champions Conference, Frankfurt a.M.
02.06.2026	RBC, Industrial Tuesday, Fireside chat
18.06.2026	ODDO BHF Forum, London

Disclaimer



This presentation serves the single purpose of introducing the RATIONAL Group and providing a brief overview. The information contained is not intended to be exhaustive and does not provide a basis for corporate decisions or serve as investment advice.

We assume no warranty, guarantee or liability for the completeness of the information, statements, estimates and projections given in this presentation, in particular with regard to the future development of the companies of the RATIONAL Group. This presentation contains assessments of the future based on the assumptions and estimates of the Executive Board of RATIONAL AG. Even though the Executive Board is convinced that these assumptions and plans are correct, the actual development and future results may significantly deviate from these assumptions and estimates. RATIONAL AG does not assume warranty or liability for future developments and future results corresponding to the assumptions and estimates made in this presentation.

Individual values and totals may differ due to rounding.

© RATIONAL 2026

RATIONAL Investor Relations

Stefan Arnold (Head of IR)
Laura Deininger (Manager IR)
ir@rational-online.com
+49 8191 327 2209